



AIR NAILER

Construction & Industry

PROFESSIONAL FRAMING NAILER

AIR NAILER

HIGH LEVER FRAMING NAILER

- Construction & Industry
- Home Improvement

21° Round Head Framing Nailer *RHF9021*

- Light weight and strong aluminum housing
- Non-slip rubber grip for comfort and better control
- Cylinder valve drive system for rapid response and increased durability
- Heat treated air inlet plug with longer life and greater drive power
- Tool-less depth of drive adjustment
- Accepts 2" - 3-1/4", 21° round head, plastic collated strip nails
- Ideal for framing, subflooring, roof decking, and wall sheathing

SPECIFICATIONS

Model No:RHF9021
Dimension:526x355x132mm(20.7"x13.97"x5.19")
Working Pressure:80-120Psi(5.5-8Bar)
Max.Pressure:120Psi(8.3Bar)
Weight:3.9Kg(7.9Lb)
Load Capacity:2x30Pcs

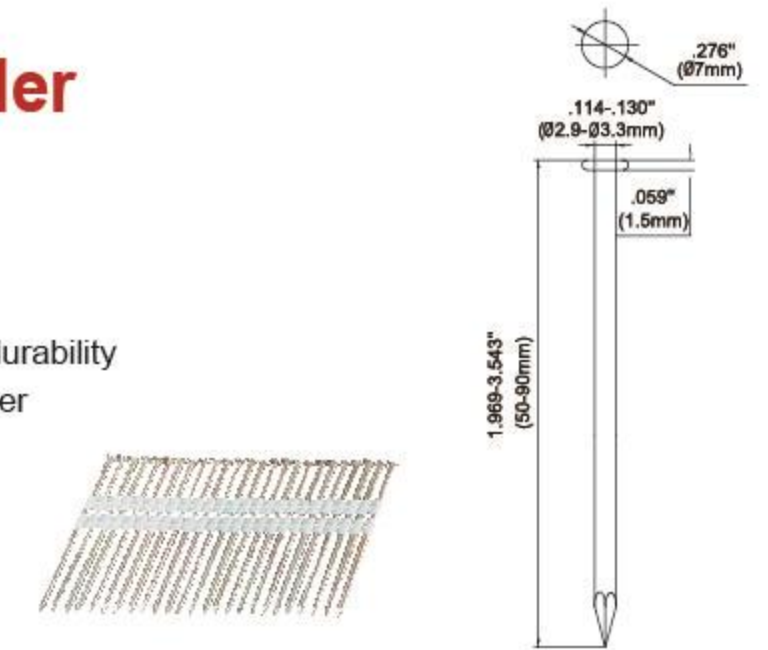

ALUMINUM HOUSING

Light weight and strong aluminum housing

TRIGGER

Available with either sequential and contact fire triggers.

Nose

Open nose design for easy extraction of a jammed nail

SOFT GRIP HANDLE

Non-slip rubber grip for comfort and better control

QUICK COUPLER

1/4" chrome quick coupler.

MAGAZINE

Spacious magazine holds up to 2x30 nails.

FRAMING NAILER

Construction & Industry
Home Improvement

AIR NAILER

- Light weight and strong aluminum housing
- Non-slip rubber grip for comfort and better control
- Heat treated air inlet plug with longer life and greater drive power
- Tool-less depth of drive adjustment
- Accepts 2" - 3-1/4", 21° round head, plastic collated strip nails
- Ideal for framing, subflooring, roof decking, and wall sheathing

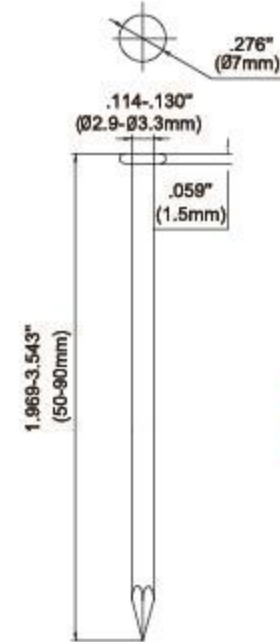

21° Round Head Framing Nailer

ARHF9021

SPECIFICATIONS

Model No:ARHF9021
Dimension:124x400x347mm
(4.88"x15.75"x13.66")
Working Pressure:80-120Psi(5.5-8Bar)
Max.pressure:120Psi(8.3Bar)
Weight:3.58Kg(7.87Lb)
Load Capacity:2x30Pcs

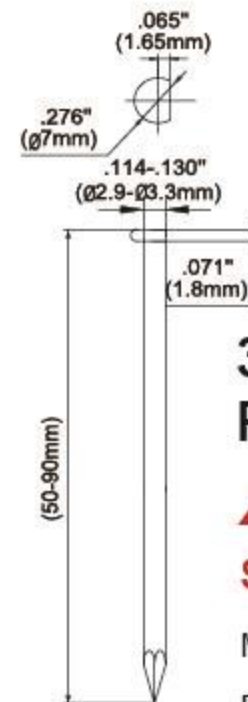

34° Clipped Head Framing Nailer

ACHF9034

SPECIFICATIONS

Model No:ACHF9034
Dimension:118x408x342mm
(4.65"x16.06"x13.46")
Operating Pressure:80-120Psi(5.5-8Bar)
Max.pressure:120Psi(8.3Bar)
Weight:3.5Kg(7.72Lb)
Load Capacity:2x40Pcs

AIR NAILER

FRAMING NAILER

Construction & Industry
Home Improvement

Coil Framing Nailer

CN83

- Heat treated aluminum Housing -- extra heavy duty industrial design.
- Selective actuation switch(sequential or bump)for convenience.
- Extra fast at the rate of 3 nails per second.
- Powerful for tough engineered lumber and pallet.
- Tool-Free precise adjustable depth of drive.
- Comfortable over-molded rubber grip.
- Single-action side-load high-capacity magazine that holds up to 200-300 coil nails and reduces downtime.
- The tool drives 15-Degree wire collated coil framing nails 2-Inch by 0.099-Inch to 3-1/4-Inch by 0.131-Inch.
- Compact body design for better balance and control.

APPLICATIONS:

- Crating, Fencing, Siding, Decking and Sheathing, Framing, subflooring.

SPECIFICATIONS

Model No:CN83	Dimension:316x360x136.5mm(12.44"x14.17"x5.37")
Weight:3.9Kg(7.9Lb)	Required Pressure:70-120Psi(4.8-8.3Bar)
Max.Presssure:120Psi(8.3Bar)	L Capacity:200~300Pcs

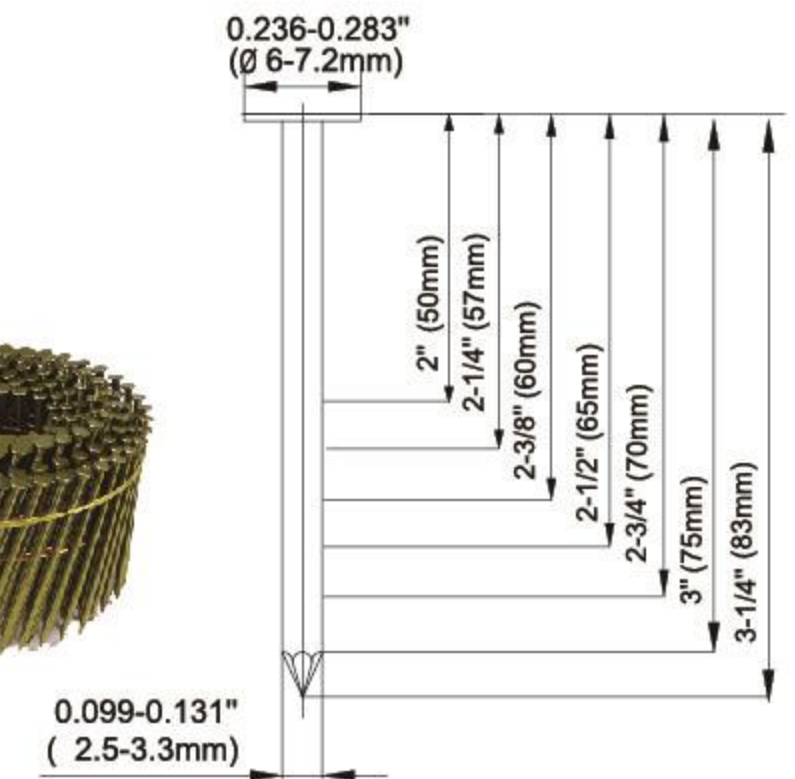

PROFESSIONAL COIL ROOFING NAILER

AIR NAILER

HIGH LEVER COIL NAILER

- Construction & Industry
- Home Improvement

CN45RA

- Nail head and drive pin have be heat treated by Ipsen which import from Germany.
- One piece drive pin working life is more 0.3 millions times.
- Can be bump fire and sequential fire.
- Jamed nail rate at about 0.03%.
- Aircraft grade bumper, resistant to wearing.
- TPE handle sheath, not easy to frost crack.
- High strength alum alloy die casting body.
- High strength plastic magazine, stand wear and tear.
- Tool free precise adjustable depth of drive.
- Safety nose will be shot under twice the weight of the gun body, for safety of operation.

SPECIFICATIONS

Model No: CN45RA

Dimension: 283x280x115mm
(11.14"x11.02"x4.52")

Required Pressure: 70-110Psi (4.8-7.5Bar)

Max. Pressure: 120Psi (8.3Bar)

Nail Capacity: 120Pcs

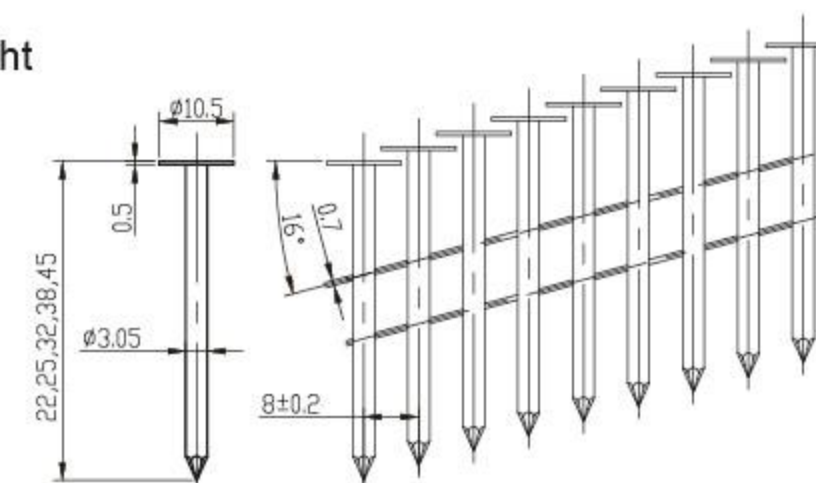

ALUMINUM HOUSING

Light weight and strong aluminum housing

TRIGGER

Available with either sequential and contact fire triggers.

Nose

Driver tip protects the working surface.

SOFT GRIP HANDLE

Non-slip rubber grip for comfort and better control

QUICK COUPLER

1/4" chrome quick coupler.

MAGAZINE

Big loading capacity magazine will fasten a full bundle of shingles without reloading.

MAGAZINE TRIGGER

Open and close magazine.



PROFESSIONAL COIL SIDING NAILER

AIR NAILER

HIGH LEVER AIR NAILER

- Construction & Industry
- Home Improvement



Coil Siding Nailer

- Lightweight and durable.
- Drives 1-1/2" to 2-1/2" 0° coil nails.
- High-capacity side-load magazine.
- Tool-less depth adjustment.
- Durable construction.

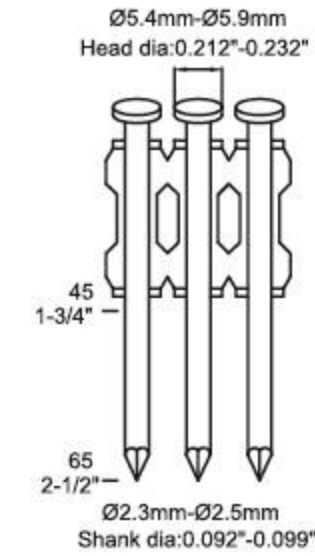

*New Design!
Light weight & Durable!*

CN65ZRA 0° Coil Siding Nailer



SPECIFICATIONS

Model No:CN65ZRA

Weight:2.3Kg(5.06Lb)

Max.Pressure:120Psi(8.3Bar)

Dimension:282x316x145mm(11.1"x12.44"x5.71")

Required Pressure:70-120Psi(4.8-8.3Bar)

Nail Capacity:300Pcs



CN65RA 15° Coil Siding Nailer *New Design! Light weight & Durable!*

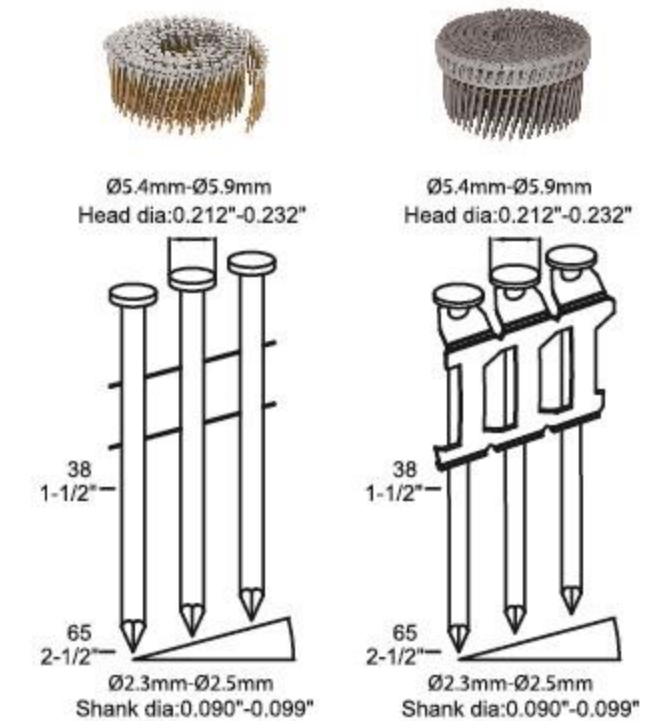

SPECIFICATIONS

Model No:CN65RA

Weight:2.3Kg(5.06Lb)

Max.Pressure:120Psi(8.3Bar)

Dimension:282x316x132mm(11.1"x12.44"x5.2")

Required Pressure:70-120Psi(4.8-8.3Bar)

Nail Capacity:250Pcs



COIL FRAMING NAILER

AIR NAILER

FRAMING NAILER

- Construction & Industry
- Home Improvement

MCN90

- Aircraft grade bumper, resistant to wearing.
- TPE handle sheath, not easy to frost crack.
- High strength aluminum alloy die casting body.
- High strength plastic magazine, stand wear and tear.

SPECIFICATIONS

Model No:MCN90
Dimension:376x356x132mm
(14.80"x14.01"x5.19")
Required Pressure:90-110Psi(6.1-7.5Bar)
Max.Pressure:120Psi(8.3Bar)
Weight:4.25Kg(9.35Lb)
Nail Capacity:225Pcs

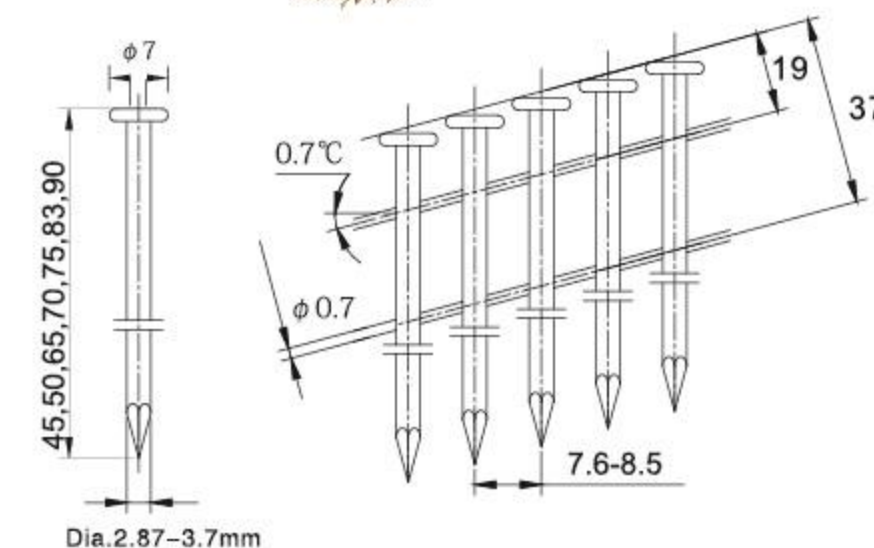

ALUMINUM HOUSING

Light weight and strong aluminum housing

TRIGGER

Available with either sequential and contact fire triggers.

Nose

Open nose design for easy extraction of a jammed nail

SOFT GRIP HANDLE

Non-slip rubber grip for comfort and better control

QUICK COUPLER

1/4" chrome quick coupler.

MAGAZINE

Big loading capacity magazine will fasten a full bundle of shingles without reloading.

MAGAZINE TRIGGER

Open and close magazine.



INDUSTRIAL COIL NAILER



M SERIES COIL PALLET NAILER

 Pallet Factory
Construction & Industry

AIR NAILER

MCN55

- Large piston with German workmanship
- Die cast aluminum body
- Light weight, well balanced
- Multi-directional exhaust
- Fires 15 degree wire-collated nails from 1"-2-1/4"
- Contact fire trigger
- Spare parts interchangeable with MAX
- Industrial grade super heavy duty coil nailer, Ideal for making pallets, packaging and crating

SPECIFICATIONS

Model No:MCN55	Dimension:283x131x270mm(11.14"x5.15"x10.62")
Weight:2.7Kg(5.94Lb)	Working Pressure:85-115Psi(5.8-8Bar)
Max.Pressure:120Psi(8.3Bar)	Load Capacity:300~350Pcs

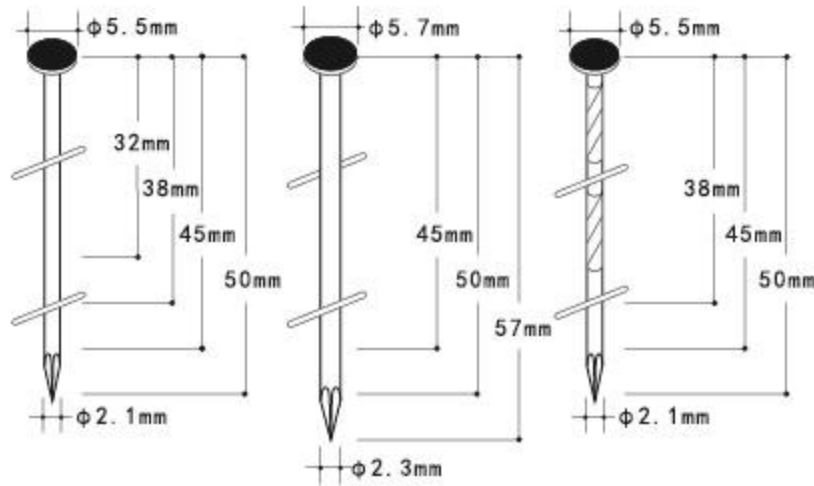
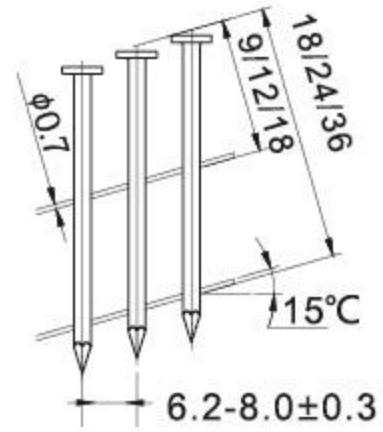

AIR NAILER

M SERIES COIL PALLET NAILER

 Pallet Factory
Construction & Industry

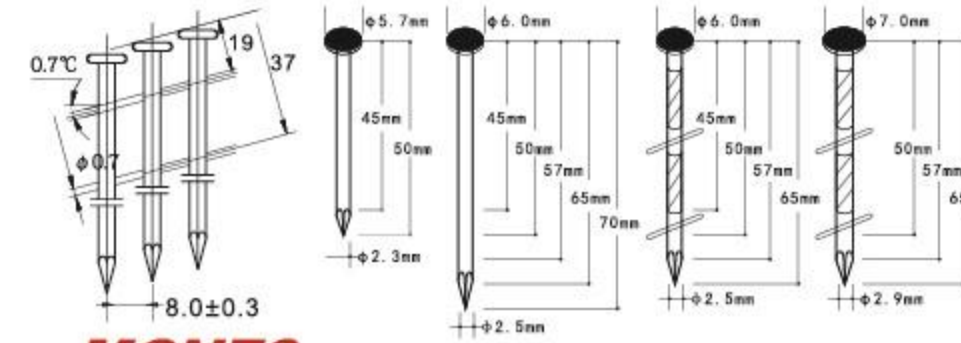

MCN70 SPECIFICATIONS

Model No.MCN70
Dimension:315x128x306mm(12.40"x5.03"x11.05")
Working Pressure:85-115Psi(5.8-8Bar)
Max.Pressure:120Psi(8.3Bar)
Weight:3.8Kg(8.36Lb)
Load Capacity:225-300Pcs

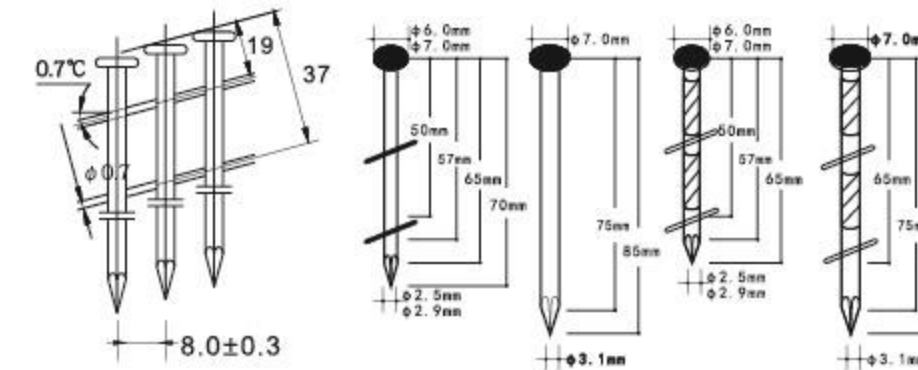

MCN80 SPECIFICATIONS

Model No.MCN80
Dimension:362x132x307mm(14.25"x5.19"x12.08")
Working Pressure:85-115Psi(5.8-8bar)
Max.Pressure:120Psi(8.3Bar)
Weight:4Kg(8.8Lb)
Load Capacity:300-350Pcs

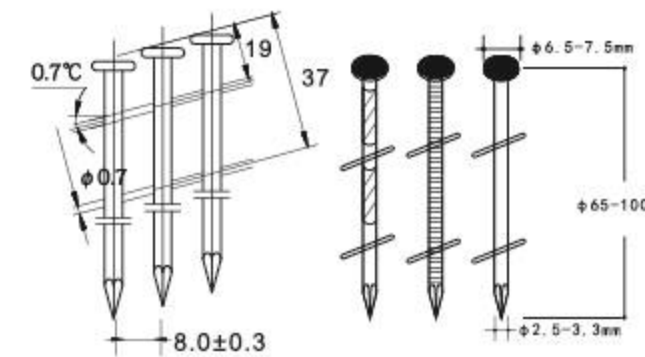

MCN100 SPECIFICATIONS



Model No.MCN100
Dimension:417x156x336mm(16.68"x6.14"x13.22")
Working Pressure:85-115Psi(5.8-8Bar)
Max.Pressure:120Psi(8.3Bar)
Weight:5.3Kg(11.6Lbs)
Load Capacity:150-300Pcs



PROFESSIONAL FINISH NAILER

AIR NAILER

FINISH NAILER

-  Construction & Industry
-  Home Improvement



AFN64

- Light weight and strong aluminum housing
- Non-slip rubber grip for comfort and better control
- 360 degree adjustable air exhaust
- Spacious magazine holds up to 100 nails
- Heat treated air inlet plug with longer life and greater drive power
- Tool-free jam release mechanism for easy nail removal
- Ideal for interior and exterior finish and trim, furniture, cabinet work, staircases, base boards, shoe and crown moulding, window casing, and chair rail moulding

SPECIFICATIONS

Model No:AFN64

Operating Pressure:80-120Psi(5.5-8.3Bar)

Weight:1.83Kg(4.07Lb)



Dimension:320x280x80mm(12.59"x11.02"x3.14")

Max.pressure:120Psi(8.3Bar)

Load Capacity:100Pcs

34° Angle Finish Nailer DA64R

- Light weight and strong aluminum housing
- Non-slip rubber grip for comfort and better control
- 360 degree adjustable air exhaust
- Spacious magazine holds up to 100 nails
- Heat treated air inlet plug with longer life and greater drive power
- Tool-free jam release mechanism for easy nail removal
- Ideal for installing cabinets, mounting crown and base moldings, window and door casings, chair rails, exterior trim and staircases, hanging shutters

SPECIFICATIONS

Model No.DA64R

Weight:2.09Kg(4.6Lb)

Max.pressure:120Psi(8.3Bar)



Dimension:320x330x80mm(12.59"x12.99"x3.14")

Required Pressure:80-120Psi(5.5-8.3Bar)

Load Capacity:100Pcs

2 IN 1 COMBI NAILER

AIR NAILER

RC SERIES NAILER

-  Construction & Industry
-  Home Improvement
-  Furniture Factory

2 In 1 Combi Nailer

- Light weight and strong aluminum housing
- Non-slip rubber grip for comfort and better control
- 360 degree adjustable air exhaust
- Spacious magazine holds up to 100 nails
- Heat treated air inlet plug with longer life and greater drive power
- Tool-free jam release mechanism for easy nail removal
- Ideal for trim work, furniture building, baseboards and crown molding installation, flooring, cabinetry, cabinet backing, window casing, picture frame assembly and other woodworking finish applications

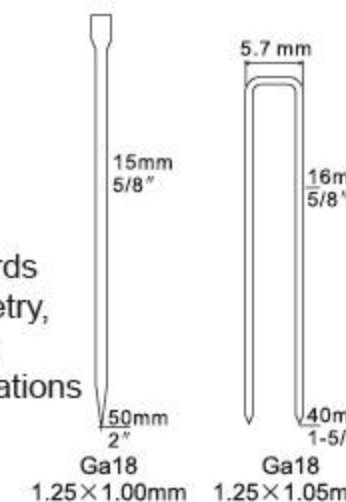

SF5040RC

SPECLIFICATIONS

Model No.SF5040RC

Weight:1.6Kg(3.52Lb)

Max.Presssure:120Psi(8.3Bar)

Dimension:283x256x60mm(11.14x10.07"x3.26")

Required Pressure:70-110Psi(4.8-7.5Bar)

Load Capacity:100Pcs

- Fastener Range:
15,20,25,30,32,
35,38,40,45,50mm



Brad Nailer

F50RC

SPECLIFICATIONS

Model No.F50RC

Weight:1.55Kg(3.41Lb)

Max.Presssure:120Psi(8.3Bar)

Dimension:283x256x60mm(11.14"x10.07"x2.36")

Required Pressure:70-110Psi(4.8-7.5Bar)

Load Capacity:100Pcs

CONCRETE NAILER

- Construction & Industry
- Home Improvement

AIR NAILER

Concrete Nailer

ST64X

- Sequential firing safe system.
- Heavy duty design with large piston allow to operate cement or steel.
- Alu.Oxidized magazine with hard-surface treatment.



Dimension: 330x275x90mm (12.99"x10.82"x3.54")

Weight: 3.3Kgs (7.26Lbs)

Load Capacity: 90Pcs

SPECLIFICATIONS

Model No: ST64X

Working pressure: 80-110Psi (5.5-7.5Bar)

Max.pressure: 120Psi (8.3Bar)

LT50

- Quick clear nose.
- No-marring rubber driver tip.
- 360 degree adjustable exhaust.
- Drive 16Ga. finish nails 3/4 inch to 2 inch.
- Heat treated aluminum housing- extra heavy duty industil design.



Dimension: 303x280x80mm (11.92"x11.02"x3.14")

Weight: 2.3Kg (5.0Lb)

Load Capacity: 90Pcs

SPECLIFICATIONS

Model No: LT50

Working pressure: 70-110Psi (4.8-7.5Bar)

Max.pressure: 120Psi (8.3Bar)

AIR NAILER

BRAD NAILER/STAPLER

- Construction & Industry
- Home Improvement
- Furniture Factory

Wide Crown Stapler

- Light weight and strong aluminum housing
- Ergonomic handle, non-slip rubber grip.
- Spacious magazine holds up to 100 nails
- Efficient contact operation

- Ideal for decorative trim, furniture trim, rail moulding, Crown moulding, window casing, door installation, base boards, chair rails, Picture frame Assembly, and hobbies and crafts

N851NP

SPECLIFICATIONS

Model No: N851NP

Dimension: 362x340x80mm (14.25"x13.38"x3.14")

Working Pressure: 70-110Psi (4.8-7.5Bar)

Max.pressure: 120Psi (8.3Bar)

Weight: 2.2Kg (4.84Lb)

Load Capacity: 150Pcs



Brad Nailer

F30F

SPECLIFICATIONS

Model No: F30F

Dimension: 260x185x68mm (10.23"x7.28"x2.67")

Working Pressure: 70-110Psi (4.8-7.5Bar)

Max.pressure: 120Psi (8.3Bar)

Weight: 1.22Kg (2.7Lb)

Load Capacity: 100Pcs



Narrow Crown Stapler

9040B

SPECLIFICATIONS

Model No: 9040B

Dimension: 303x274x81mm (11.92"x10.78"x3.18")

Working Pressure: 70-110Psi (4.8-7.5Bar)

Max.pressure: 120Psi (8.3Bar)

Weight: 2.54Kg (5.5Lb)

Load Capacity: 100Pcs

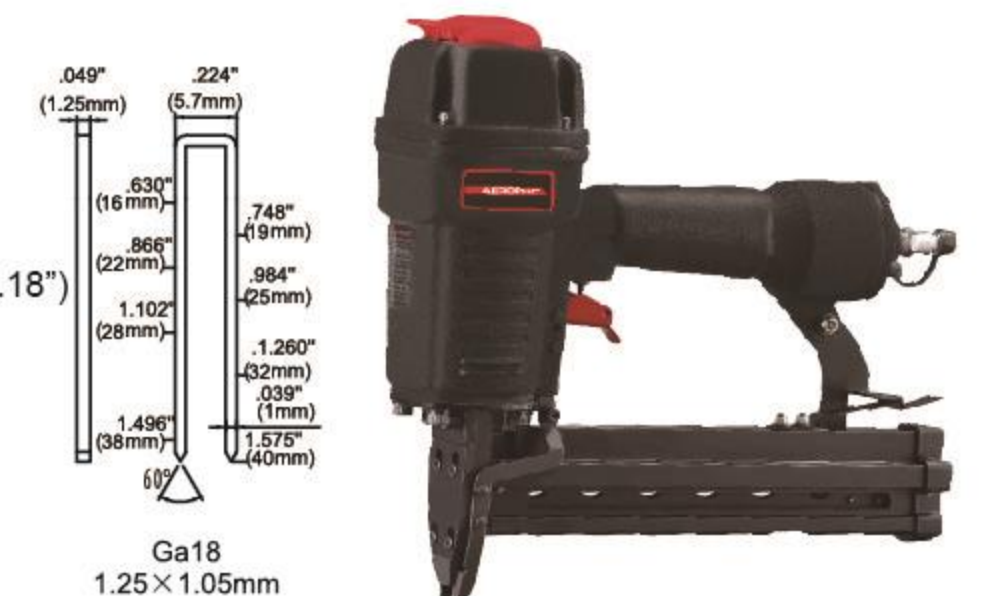

WIDE CROWN STAPLER

AIR NAILER

WIDE CROWN STAPLER

-  Construction & Industry
-  Home Improvement
-  Furniture Factory

Wide Crown Stapler

- Light weight and strong aluminum housing
- Non-slip rubber grip and plastic trigger for comfort and better control.
- Magazine release knob, easy to use.
- Aluminum alloy magazine with large capacity.
- Heat-treated cylinder cover with hammer function
- High quality piston with increased life up to 1000000 cycles.
- Ideal for lathing, sheathing, insulation installation, cabinetry, upholstery, furniture and frame construction, industrial packaging, joinery, measurement and assembly construction

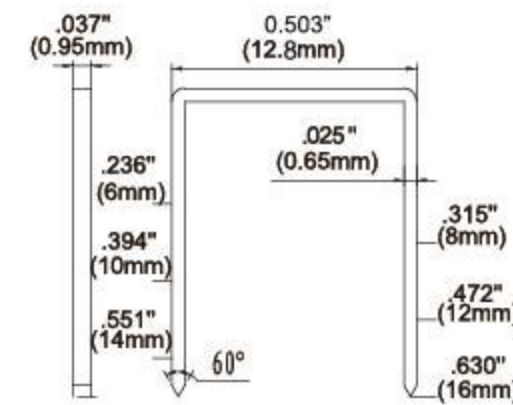

A8016 SPECIFICATIONS

Model No:A8016	Dimension:220.5x140.5x43.2mm(8.68"x5.51"x1.70")
Working pressure:72-87Psi(5-6Bar)	Weight:0.91Kg(2.0Lb)
Max.pressure:120Psi(8.3Bar)	Load Capacity:125Pcs

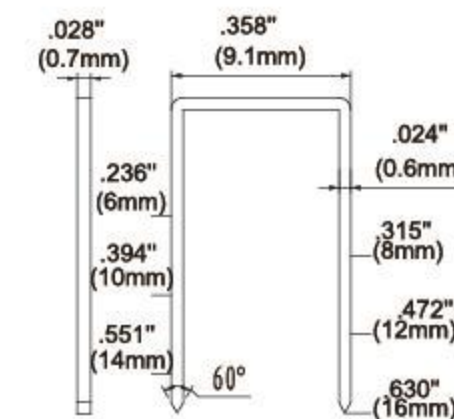

A7116 SPECIFICATIONS

Model No:A7116	Dimension:220.5x140.5x43.2mm(8.68"x5.51"x1.70")
Working pressure:72-87Psi(5-6Bar)	Weight:0.91Kg(2.0Lb)
Max.pressure:120Psi(8.3Bar)	Load Capacity:157Pcs



STAPLER

- Construction & Industry
- Home Improvement
- Furniture Factory

AIR NAILER

Ga20 Wide Crown Stapler

- Alum die casting gun body.
- Easily open magazine latch for fast loading by one hand.
- Working life of drive pin is over 150 thousand times.
- Aviation grade bumper.
- Sequential fire.
- TPE handle sheath, hard to frost crack.
- Wear resistant hard anodized alum magazine.

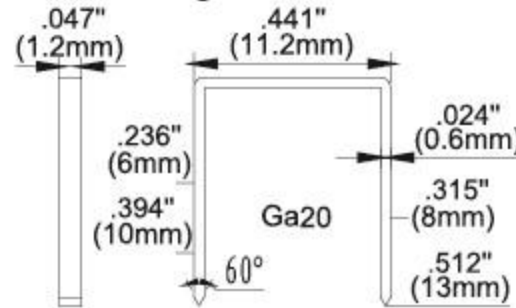

1013J

SPECLFICATIONS

Model No:1013J

Dimension:210x145x45mm(8.26"x5.70"x1.77")

Weight:0.9Kg(1.9Lb)

Working pressure:70-110Psi(4.8-7.5Bar)

Max.pressure:120Psi(8.3Bar)

Load Capacity:70Pcs

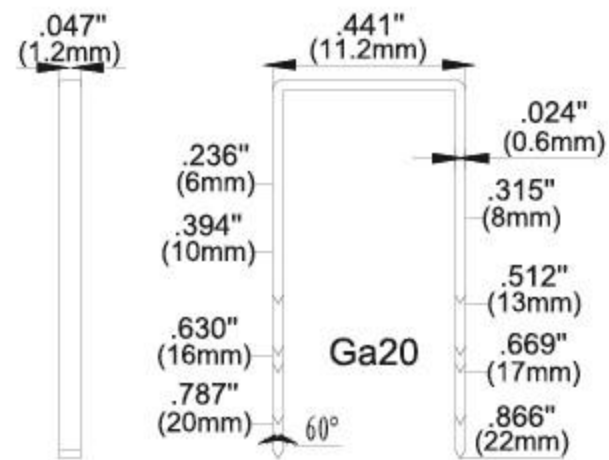

1022J

SPECLFICATIONS

Model No:1022J

Dimension:241x186x54mm(9.48"x7.32"x2.12")

Weight:1.25Kg(2.71Lb)

Working pressure:70-110Psi(4.8-7.5Bar)

Max.pressure:120Psi(8.3Bar)

Load Capacity:100Pcs

AIR NAILER

AIR PIN NAILER/PALM NAILER

- Construction & Industry
- Home Improvement
- Furniture Factory

Pin Nailer

H625

- Headless pin for perfect decoration without mark.
- Nail length regular automatically to desire pin length.
- Complicate with: Senco finish pro 10, Accuset a 100mp, porter cable pin100.

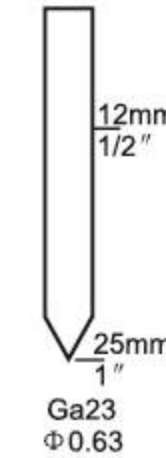

SPECLFICATIONS

Model No:H625

Dimension:215x162x45mm(8.46"x6.37"x1.77")

Weight:1.0Kg(2.2Lb)

Working pressure:60-100Psi(4-7Bar)

Max.pressure:120Psi(8.3Bar)

Load Capacity:140Pcs

Air Palm Nailer

MSN90

- Magnetic nose holds a fastener in place for safe and accurate fastener placement
- Accepts a 2-1/2" - 3-1/2" bulk fasteners
- Light weight for easy maneuverability
- 360 Degree swivel fitting for maximum maneuverability and ease of use
- Ideal for installing Joist hangers and metal connectors



SPECLFICATIONS

Model No:MSN90

Dimension:103x53x103mm(4.05"x2.08"x4.05")

Weight:0.35Kg(0.8Lb)

Working pressure:70-100Psi(5-7Bar)

Max.pressure:120Psi(8.3Bar)

Load Capacity:1Pcs

2 IN 1 FLOORING NAILER

AIR NAILER

FLOORING NAILER

- Construction & Industry
- Home Improvement

3 In 1 Flooring Nailer 9800RC

- L, T or staple configuration.
- Ergonomic design with longer handle for easy operation.
- Composite base to eliminate scratch and damage to the surface of the wood.
- Non-Marring base is designed to allow driving of fastener close to wall.
- Using no cylinder structure, the life of the product is longer.

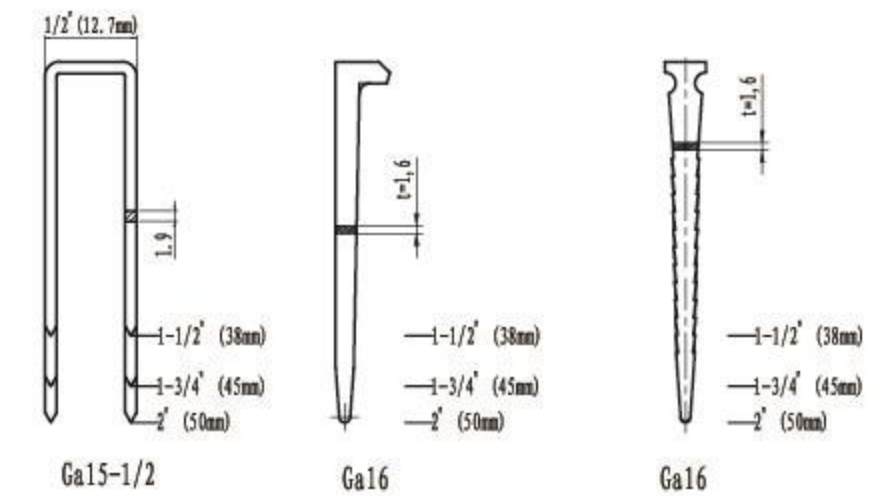

SPECIFICATIONS

Model No:9800RC

Dimension:489×495×90mm(19.25"×19.49"×3.54")

Working pressure:80-120Psi(5.5-8Bar)

Weight:4.54kg

Max.pressure:120Psi(8.3Bar)

Load Capacity:100Pcs

LIGHT-STRIKE BUMPER

Light-Strike Bumper for Ease of Use and Reducing Fatigue.

HEAVY-DUTY HOUSING

Industrial Designed, Heat Treated, Heavy-Duty Housing.

COMFORT RUBBER GRIP

Long-Reach Handle and Ergonomic Rubber Grip Adds Comfort and Control.

ANODIZED ALUMINUM MAGAZINE

High Quality Magazine Holds 100 Pieces of Any Compatible Fasteners.

CARTON CLOSING STAPLER

AIR NAILER

CARTON CLOSING STAPLER

 Carton Factory

MTA18

- Light weight and strong aluminum housing
- Ergonomic handle, non-slip rubber grip
- Spacious magazine holds up to 100 nails
- Fasteners length adjustable
- Depth of Clinch and Penetration Adjustable
- Ideal for folding boxes, complete overlap and other corrugated cardboard applications

SPECIFICATIONS

Model No:MTA18

Dimension:346x227x145mm(13.62"x8.94"x5.71")

Working Pressure:70-100Psi(5-7Bar)

Max.Pressure:120Psi(8.3Bar)

Weight:2.7Kg(5.94Lb)

Load Capacity:100Pcs



ALUMINUM HOUSING

Light weight and strong aluminum housing

DEPTH ADJUSTABLE

Depth of Clinch and Penetration Adjustable

FASTENERS ADJUSTABLE

Fasteners length adjustable

SOFT GRIP HANDLE

Ergonomic handle, non-slip rubber grip

QUICK COUPLER

1/4" chrome quick coupler.

BIG LOAD AIR CONTAINER

Big load air container makes the tool more powerful.

MAGAZINE

Spacious magazine holds up to 100 nails



PNEUMATIC RIVET GUN

Construction & Industry
Automotive Repair & Maintenance

AIR Rivet Gun

Air Rivet Gun

P70

Lightweight design reduces user fatigue for prolonged use.

Pneumatic riveter features a transparent container with holes for quick release of rivet ends. Compact design of air-powered tool allows the operator to use it in tight spaces. Handheld tool allows easy pulling up to 2200 lbs. Simple construction of the riveter ensures easy maintenance

The AeroPro P70 air rivet gun is designed for heavy duty industrial application of rivets from 3/32 to 3/16-inch. This tool will increase productivity in any field. Range of use includes industrial, automotive and constructionFabrication shops and body shops.



RIVET SIZES	PULLING POWER	AIR	AIR COMPRESSOR	AIR INLET	MIN.HOSE SIZE
3/32, 1/8, 5/32, 3/16in. (2.4, 3.2, 4.0, 4.8mm)	2000 lbs. 907 kgm	0.2 CFM 6 L/min	2 Gal.or Larger	1/4 in.	1/4 in. 7,6 mm

AIR NAILER

AIR NAILER KITS

Construction & Industry
Home Improvement

AP9209-A

- 1 pc AFN64 Finish Nailer
- 1 pc F50RC Brad Nailer
- 1 pc 9025RC Narrow Stapler
- 3 pcs Hex Key wrenches
- 1 pc Safety Goggle
- 1 pc Oil
- 1 pc Blow Case



AP9202-A

- 1 pc F50RC Brad Nailer
- 1 pc A8016 Air Stapler
- 1 pc Safety Glasses
- 1 pc Oil Pot
- 2 pcs Hex Key Wrenches
- 1 pc Blow Case



AP9200-A

- 1 pc RHF9021 Framing Nailer
- 1 pc AFN64 Finish Nailer
- 1 pc F50RC Brad Nailer
- 1 pc Oil Pot
- 4 pcs Hex Key Wrenches
- 2 pcs No-mar Tip
- 3 pcs One-thousand Nails
- 1 pc Blow Case

